

BLV SERIES LOW VOLTAGE PRESSURE SENSORS

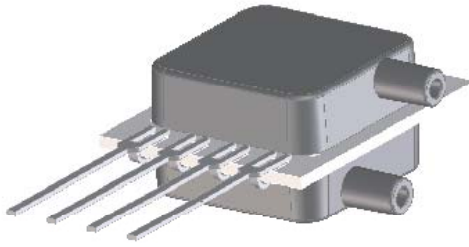

Features

- 0 to 1 "H₂O to 0 to 30 "H₂O Pressure Ranges
- uPower Low Supply Voltage (0.9V to 1.8V)
- 90% Less Power Than Mini-Basic Series
- 0.3% Linearity
- Improved Front to Back Linearity
- Excellent Position Sensitivity
- Improved Warm-Up Shift Distribution
- Parylene Coating Available Upon Request

Applications

- Medical Instrumentation
- Environmental Controls
- HVAC
- Portable / Hand Held Devices

General Description

The BLV Series Basic Sensor is based on All Sensors' CoBeam²™ Technology. The device provides a high output signal at a low operating voltage and reduces the overall supply voltage while maintaining comparable output levels to traditional equivalent basic sensing elements. This lower supply voltage gives rise to improved warm-up shift while the CoBeam² Technology itself reduces package stress susceptibility resulting in improved overall long term stability. The technology also vastly improves position sensitivity compared to conventional single die devices.

This series is intended for use with non-corrosive, non-ionic working fluids such as air, dry gases and the like. The output is also ratiometric to the supply voltage and is operable from 0.9 to 1.8 volts DC.

Standard Pressure Ranges				Equivalent Circuit
Device	Operating Range	Proof Pressure	Burst Pressure	
BLV-L01D	±1 inH ₂ O	100 inH ₂ O	300 inH ₂ O	
BLV-L05D	±5 inH ₂ O	200 inH ₂ O	300 inH ₂ O	
BLV-L10D	±10 inH ₂ O	200 inH ₂ O	300 inH ₂ O	
BLV-L20D	±20 inH ₂ O	200 inH ₂ O	500 inH ₂ O	
BLV-L30D	±30 inH ₂ O	200 inH ₂ O	800 inH ₂ O	

Pressure Sensor Maximum Ratings		Environmental Specifications	
Supply Voltage (Vs)	6 Vdc	Temperature Ranges	
Common Mode Pressure	5 psig	Operating	-25 to 85 °C
Lead Temperature (soldering 2-4 sec.)	270 °C	Storage	-40 to 125 °C
		Humidity Limits	0 to 95% RH (non condensing)

Approvals

MKT	DATE	MFG	DATE	ENG	DATE	QA	DATE
<input type="checkbox"/> As Is <input type="checkbox"/> With Change		<input type="checkbox"/> As Is <input type="checkbox"/> With Change		<input type="checkbox"/> As Is <input type="checkbox"/> With Change		<input type="checkbox"/> As Is <input type="checkbox"/> With Change	



Performance Characteristics for BLV Series

ALL PARAMETERS ARE MEASURED AT 1.8 VOLT EXCITATION AND ROOM TEMPERATURE UNLESS OTHERWISE SPECIFIED. PRESSURE MEASUREMENTS ARE WITH POSITIVE PRESSURE APPLIED TO PORT B (THE ONLY PORT FOR THE SINGLE PORT CONFIGURATION).

Parameter	Min	Typ	Max	Units	Notes
Output Span					
L01D @ 1 inH2O	4.5	8.0	11.5	mV	4
L05D @ 5 inH2O	13.5	24.0	34.5	mV	4
L10D @ 10 inH2O	18.0	32.0	46.0	mV	4
L20D @ 20 inH2O	22.0	38.0	55.0	mV	4
L30D @ 30 inH2O	25.0	42.0	60.0	mV	4
Offset Voltage @ Zero Diff. Pressure	-	-	±10	mV	-
Offset Temperature Shift (0°C-70°C)	-	-25.0	-	uV/°C	1
Offset Warm-up Shift	-	±20.0	±100	uV	2
Offset Position Sensitivity (1g)	-	±20.0	-	uV	-
Offset Long Term Drift (One Year)	-	±120	-	uV	-
Linearity, Hysteresis Error	-	0.10	±0.30	%FSS	3
Response Time (10% to 90% Pressure Response)	-	100	-	uS	-
Front to Back Linearity	-	0.25	-	%FSS	5
Temperature Effect on Resistance (0°C-70°C)	-	2800	-	ppm/°C	-
Temperature Effect on Span (0°C-70°C)	-	-1900	-	ppm/°C	-
Input Resistance	-	3.0	-	k ohm	-
Output Resistance	-	3.0	-	k ohm	-

Specification Notes

NOTE 1: SHIFT IS RELATIVE TO 25°C.

NOTE 2: SHIFT IS WITHIN THE FIRST HOUR OF EXCITATION APPLIED TO THE DEVICE.

NOTE 3: MEASURED AT ONE-HALF FULL SCALE RATED PRESSURE USING BEST STRAIGHT LINE CURVE FIT.

NOTE 4: THE SPAN IS THE ALGEBRAIC DIFFERENCE BETWEEN FULL SCALE OUTPUT VOLTAGE AND THE OFFSET VOLTAGE.

NOTE 5: FRONT-BACK LINERITY COMPUTED AS:
$$\text{Lin}_{FB} = \left(\frac{\text{Span}_{\text{Front}}}{\text{Span}_{\text{Back}}} - 1 \right) \cdot 100\%$$

How To Order

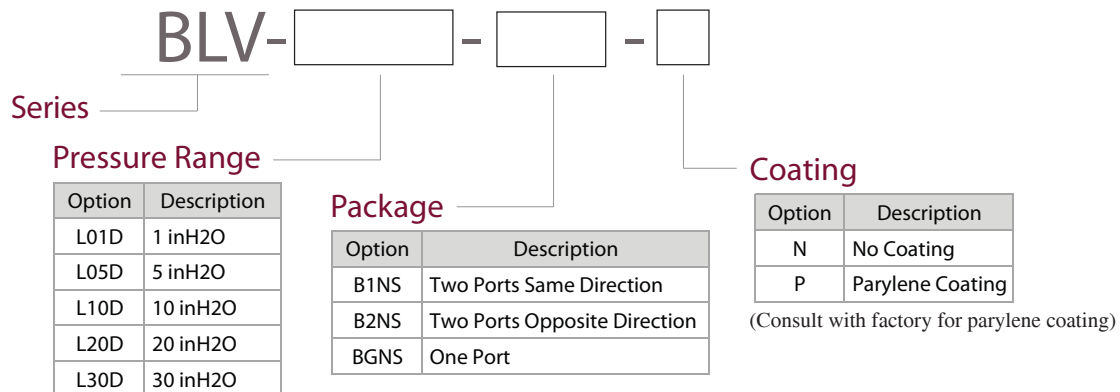

Example: BLV-L10D-B1NS-N

Package Drawings

B1NS Package

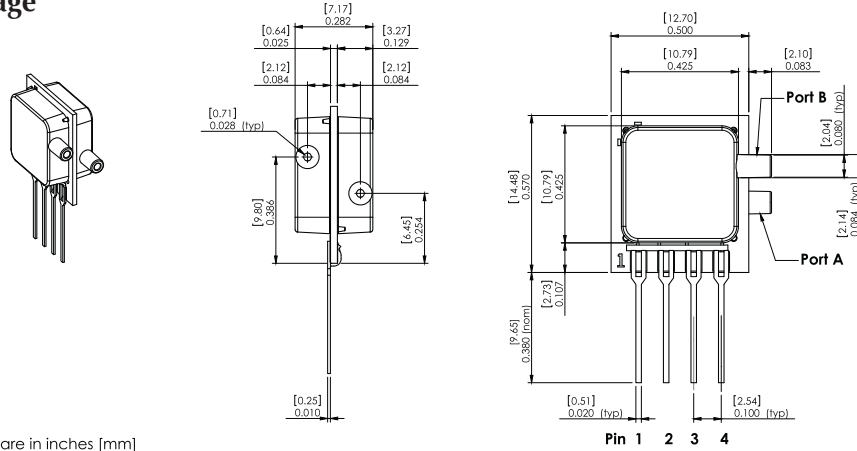

NOTES
 1) Dimensions are in inches [mm]
 2) For suggested pad layout, see drawing: PAD-01

Pinout
 1) Gnd
 2) -Out
 3) Vs
 4) +Out

B2NS Package

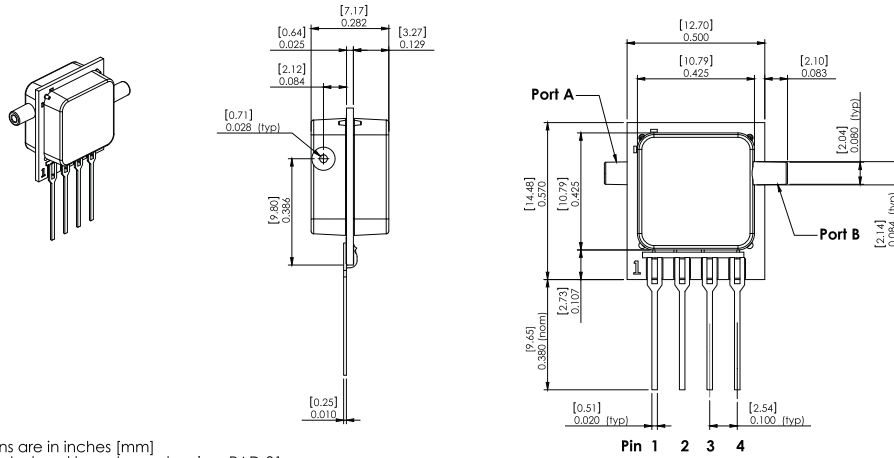

NOTES
 1) Dimensions are in inches [mm]
 2) For suggested pad layout, see drawing: PAD-01

Pinout
 1) Gnd
 2) -Out
 3) Vs
 4) +Out

BGNS Package

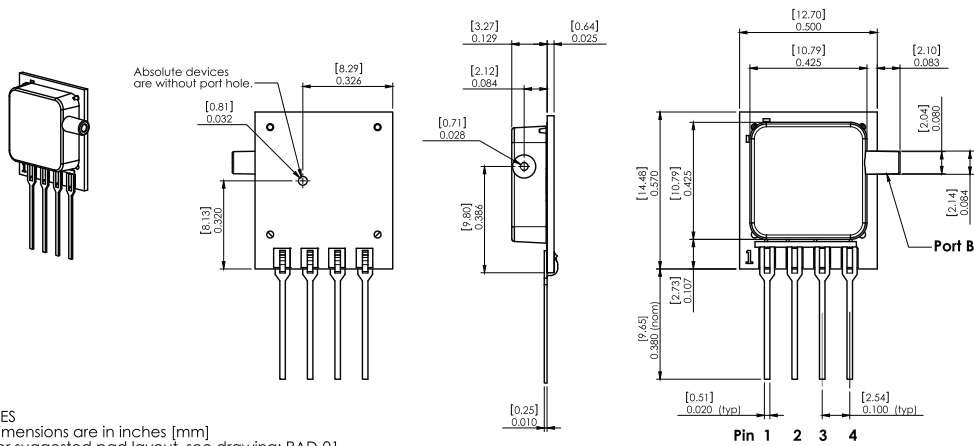

NOTES
 1) Dimensions are in inches [mm]
 2) For suggested pad layout, see drawing: PAD-01

Pinout
 1) Gnd
 2) -Out
 3) Vs
 4) +Out



Suggested Pad Layout

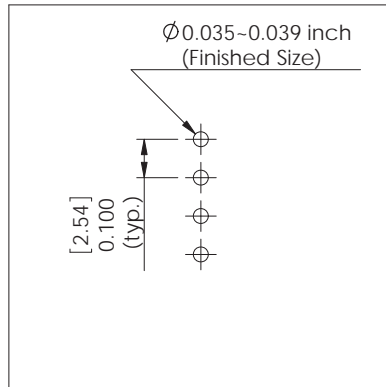

PAD-01

Package Characteristics

Package ID	Approximate Port Volume			Weight	Units
	Port A	Port B	Units		
B1NS	181	176	mm ³	1.2	Grams
B2NS	181	176	mm ³	1.2	Grams
BGNS	1.5	176	mm ³	0.9	Grams

Product Labeling

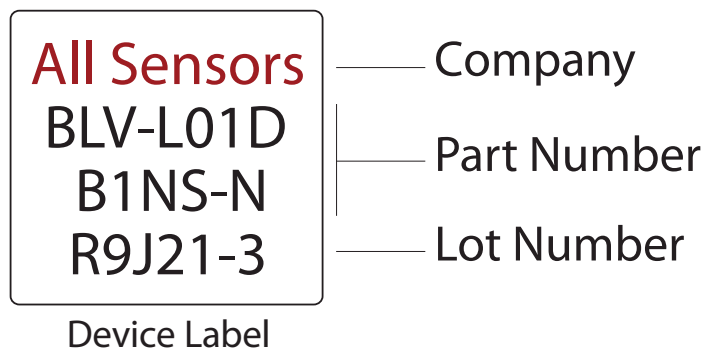

All Sensors reserves the right to make changes to any products herein. All Sensors does not assume any liability arising out of the application or use of any product or circuit described herein, neither does it convey any license under its patent rights nor the rights of others.